

International
IR Rectifier

10BQ015PbF

SCHOTTKY RECTIFIER

1 Amp

$$I_{F(AV)} = 1.0\text{Amp}$$

$$V_R = 15\text{V}$$

Major Ratings and Characteristics

Characteristics	Values	Units
$I_{F(AV)}$ Rectangular waveform	1.0	A
V_{RRM}	15	V
I_{FSM} @ $t_p = 5\mu\text{s}$ sine	140	A
V_F @1.0Apk, $T_J = 125^\circ\text{C}$	0.32	V
T_J range	-55 to 125	$^\circ\text{C}$

Description/ Features

The 10BQ015PbF surface mount Schottky rectifier has been designed for applications requiring low forward drop and very small foot prints on PC boards. The proprietary barrier technology allows for reliable operation up to 125°C junction temperature. Typical applications are in disk drives, switching power supplies, converters, free-wheeling diodes, battery charging, and reverse battery protection.

- 125°C T_J operation ($V_R < 5\text{V}$)
- Optimized for OR-ing applications
- Ultra low forward voltage drop
- High frequency operation
- Guard ring for enhanced ruggedness and long term reliability
- High purity, high temperature epoxy encapsulation for enhanced mechanical strength and moisture resistance
- Lead-Free ("PbF" suffix)

Case Styles

10BQ015PbF

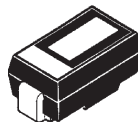

SMB



Voltage Ratings

Part number	10BQ015PbF
V_R Max. DC Reverse Voltage (V)	15
V_{RWM} Max. Working Peak Reverse Voltage (V)	25

Absolute Maximum Ratings

Parameters	10BQ	Units	Conditions
$I_{F(AV)}$ Max. Average Forward Current * See Fig. 5	1.0	A	50% duty cycle @ $T_L = 84^\circ\text{C}$, rectangular wave form.
I_{FSM} Max. Peak One Cycle Non-Repetitive Surge Current * See Fig. 7	140	A	5 μs Sine or 3 μs Rect. pulse
	40		10ms Sine or 6ms Rect. pulse
E_{AS} Non-Repetitive Avalanche Energy	1.0	mJ	$T_J = 25^\circ\text{C}$, $I_{AS} = 1\text{A}$, $L = 2\text{mH}$
I_{AR} Repetitive Avalanche Current	1.0	A	Current decaying linearly to zero in 1 μsec Frequency limited by T_J max. $V_A = 1.5 \times V_R$ typical

Electrical Specifications

Parameters	10BQ	Units	Conditions
V_{FM} Max. Forward Voltage Drop (1) * See Fig. 1	0.35	V	@ 1.0A
	0.44	V	@ 2.0A
	0.32	V	@ 1.0A
	0.40	V	@ 2.0A
I_{RM} Max. Reverse Leakage Current (1) * See Fig. 2	0.5	mA	$T_J = 25^\circ\text{C}$
	12	mA	$T_J = 100^\circ\text{C}$
$V_{F(TO)}$ Threshold Voltage	-	V	$T_J = T_J$ max.
r_t Forward Slope Resistance	-	m Ω	
C_T Typical Junction Capacitance	390	pF	$V_R = 5V_{DC}$, (test signal range 100KHz to 1MHz) 25°C
L_S Typical Series Inductance	2.0	nH	Measured lead to lead 5mm from package body
dv/dt Max. Voltage Rate of Change	10000	V/ μs	(Rated V_R)

(1) Pulse Width < 300 μs , Duty Cycle < 2%

Thermal-Mechanical Specifications

Parameters	10BQ	Units	Conditions
T_J Max. Junction Temperature Range (*)	-55 to 125	$^\circ\text{C}$	
T_{stg} Max. Storage Temperature Range	-55 to 150	$^\circ\text{C}$	
R_{thJL} Max. Thermal Resistance Junction to Lead (**)	36	$^\circ\text{C}/\text{W}$	DC operation (See Fig. 4)
R_{thJA} Max. Thermal Resistance Junction to Ambient	80	$^\circ\text{C}/\text{W}$	DC operation
wt Approximate Weight	0.10 (0.003)	g (oz.)	
Case Style	SMB		Similar to DO-214AA
Device Marking	IR1C		

(*) $\frac{dP_{tot}}{dT_J} < \frac{1}{R_{th(j-a)}}$ thermal runaway condition for a diode on its own heatsink

(**) Mounted 1 inch square PCB

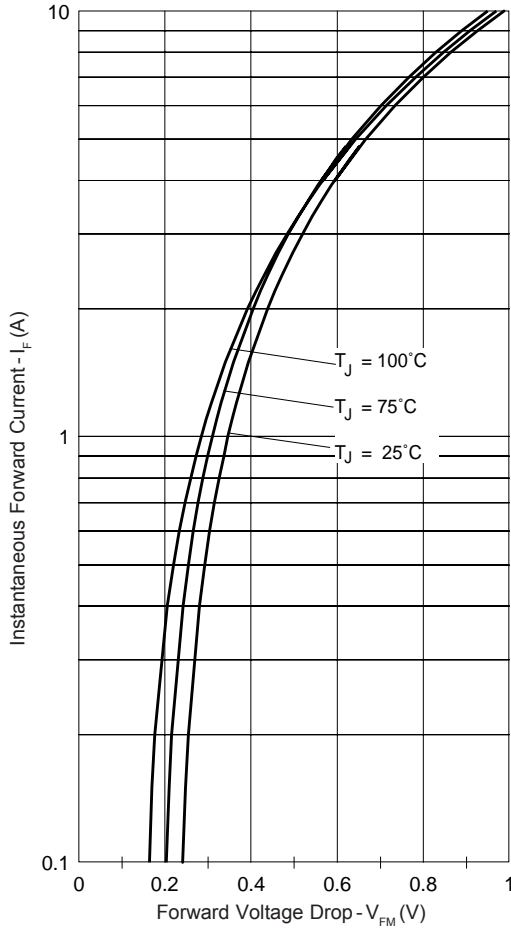

Fig. 1 - Max. Forward Voltage Drop Characteristics

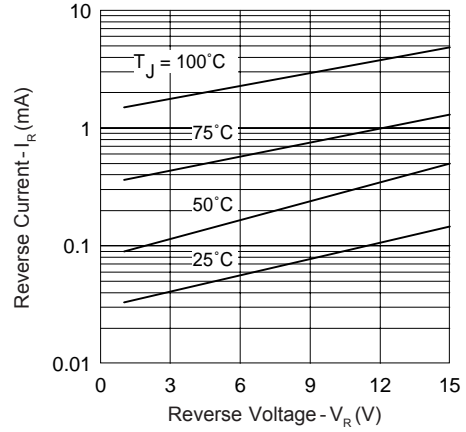

Fig. 2 - Typical Values Of Reverse Current Vs. Reverse Voltage

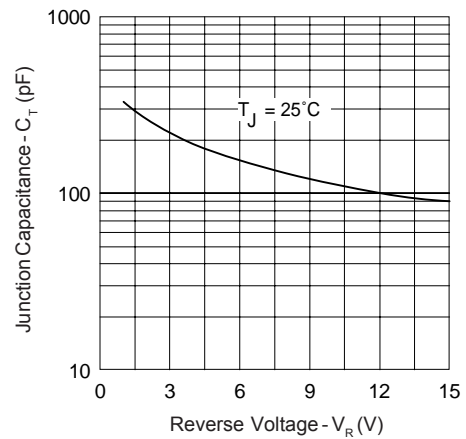

Fig. 3 - Typical Junction Capacitance Vs. Reverse Voltage

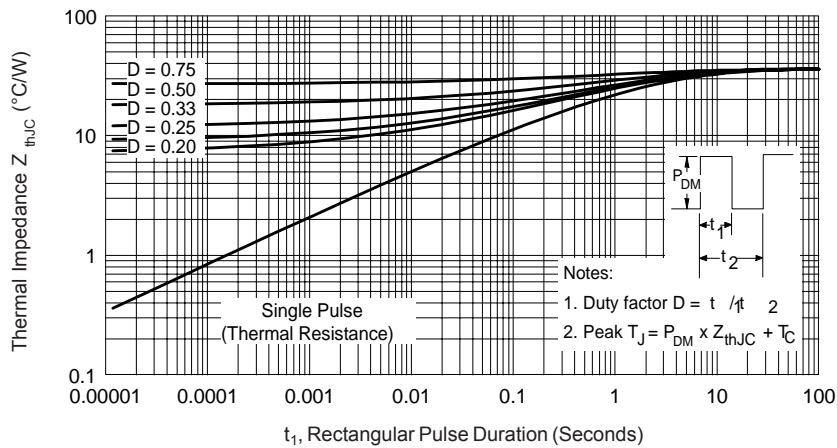

Fig. 4 - Max. Thermal Impedance Z_{thJC} Characteristics (Per Leg)

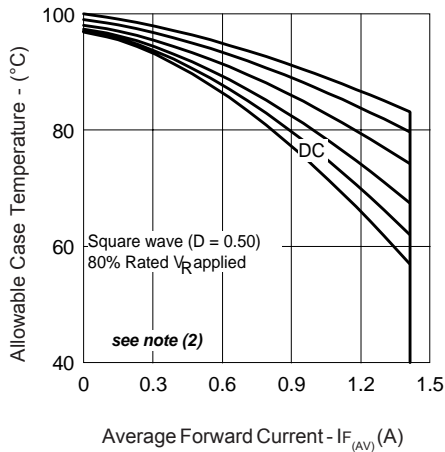

Fig. 5 - Max. Allowable Case Temperature Vs. Average Forward Current

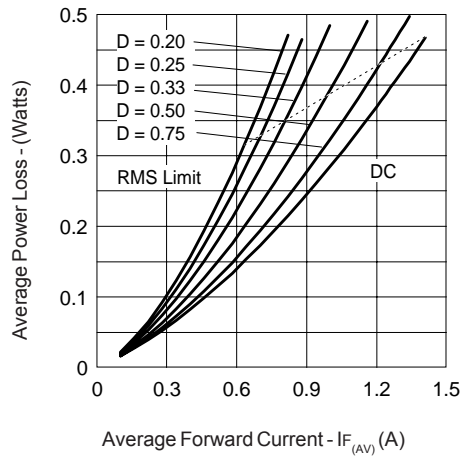

Fig. 6 - Forward Power Loss Characteristics

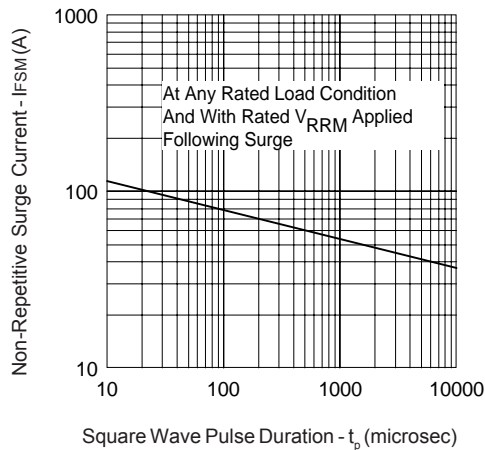
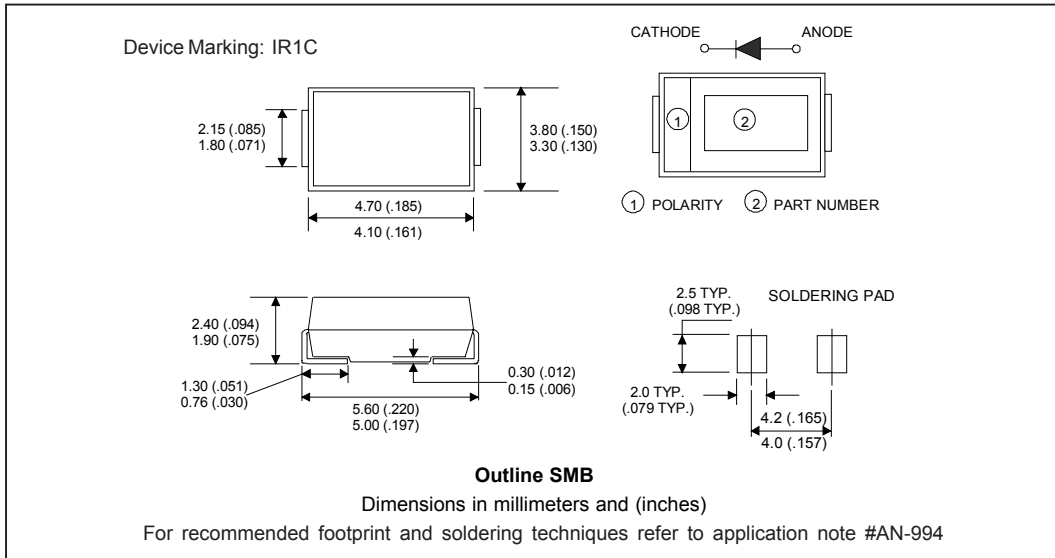

Fig. 7 - Max. Non-Repetitive Surge Current

(2) Formula used: $T_C = T_J - (Pd + Pd_{REV}) \times R_{thJC}$;
 Pd = Forward Power Loss = $I_{F(AV)} \times V_{FM} @ (I_{F(AV)} / D)$ (see Fig. 6);
 Pd_{REV} = Inverse Power Loss = $V_{R1} \times I_R (1 - D)$; $I_R @ V_{R1} = 80\%$ rated V_R

Outline Table



Marking & Identification

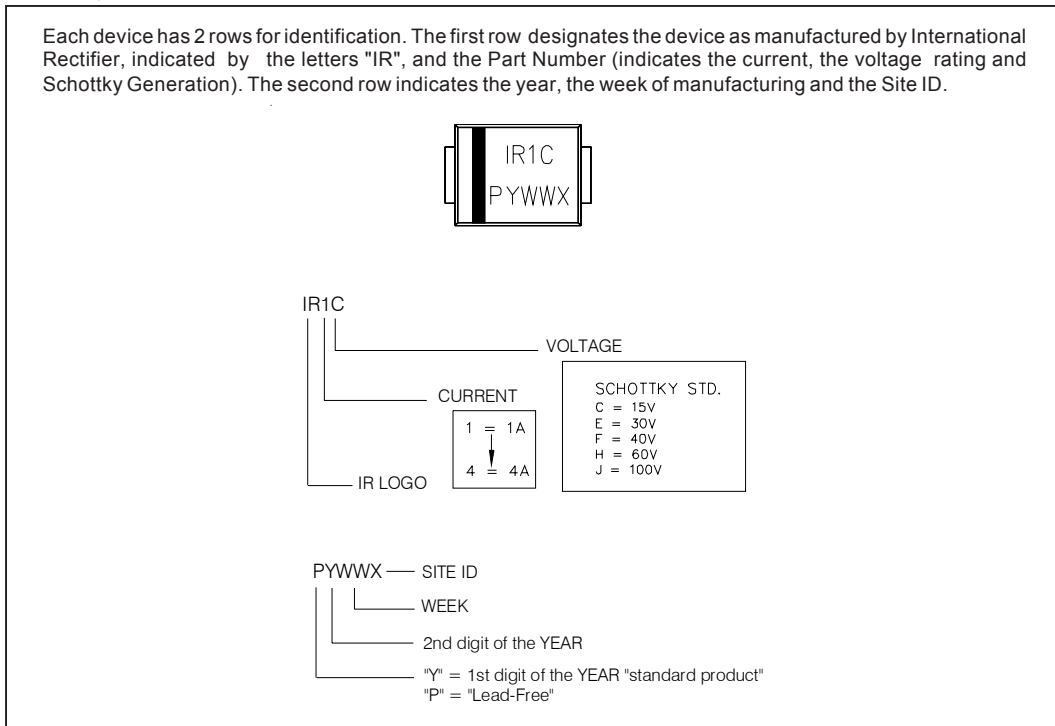

Tape & Reel Information

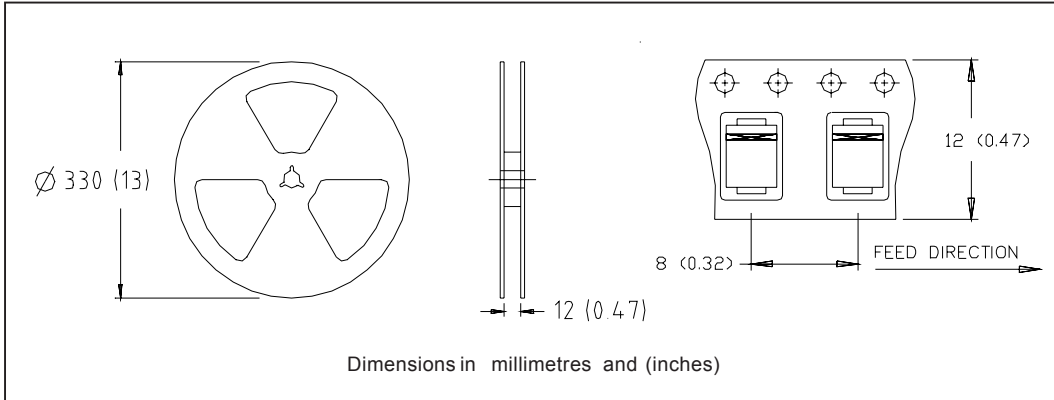

Ordering Information Table

Device Code					
10	B	Q	015	TR	PbF
①	②	③	④	⑤	⑥
1	- Current Rating				
2	- B = Single Lead Diode				
3	- Q = Schottky Q Series				
4	- Voltage Rating (015 = 15V)				
5	<ul style="list-style-type: none"> • none = Box (1000 pieces) • TR = Tape & Reel (3000 pieces) 				
6	<ul style="list-style-type: none"> • none = Standard Production • PbF = Lead-Free 				

Data and specifications subject to change without notice.
This product has been designed and qualified for Industrial Level and Lead-Free.
Qualification Standards can be found on IR's Web site.